



Converter Accessory Corporation
www.converteraccessory.com



Core Locking / Holding Systems
www.cor-lok.com



CAC's COR-LOK air shafts and chucks are manufactured under US Patent number 3825167, 3917187, 3937412, 4124173

COR-LOK® Air Chucks - B2 Series with PTV inflating valve



Unique Air Chuck for Unwinding and Rewinding

COR-LOK air chucks are different. Their unique design provides high-torque core locking with zero core damage. COR-LOK B2 series air chucks utilize inflating tube engineered to fit the COR-LOK spiral internal housing. Inflating the air chucks with pressurized air will actuate COR-LOK's interlocking segments to engage the core and lock it in place. These interlocking segments expand evenly around the circumference and across the width of the core, ensuring even torque distribution in the core's inside diameter. This means your cores will not slip and will not distort during the unwind / rewind process.

Standard air chucks are supplied with thru bores. They may be mounted to any thru bar / shaft; locked in place with CAC's unique split bushing design. Standard air chucks may be used in cantilevered and dual support applications.

- **Lightweight** - easy to use
- Interlocking segment design is easy to slide in and out of cores for fast roll changes
- Perfect replacement / upgrade from tire chucks
- High torque output to ensure your cores stay locked - **no core slipping**
- Interlocking segment design insures zero core damage
- Engineered inflating tube (bladderless)
- **Low Maintenance** - built to last!
- **15 Minute** maintenance
- 3" - 12" Diameter cores
- Industry standard inflation valve (PTV type)
- Aluminum (standard), steel, stainless steel and carbon fiber construction available
- Thru bore design (standard)
- **Standard designs**
- Combine with CAC's unwind and rewind modules for a complete engineered solution
- Stocked for 3" and 6" diameter cores - check CAC's stock list at www.converteraccessory.com
- **Made in the USA!**



Inside CAC's COR-LOK® B2-Series Air Chucks

Core Locking / Holding Systems
www.cor-lok.com

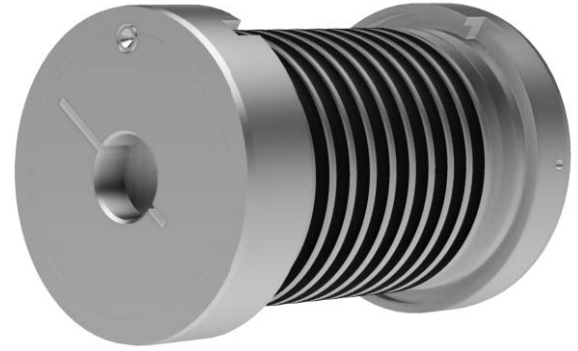
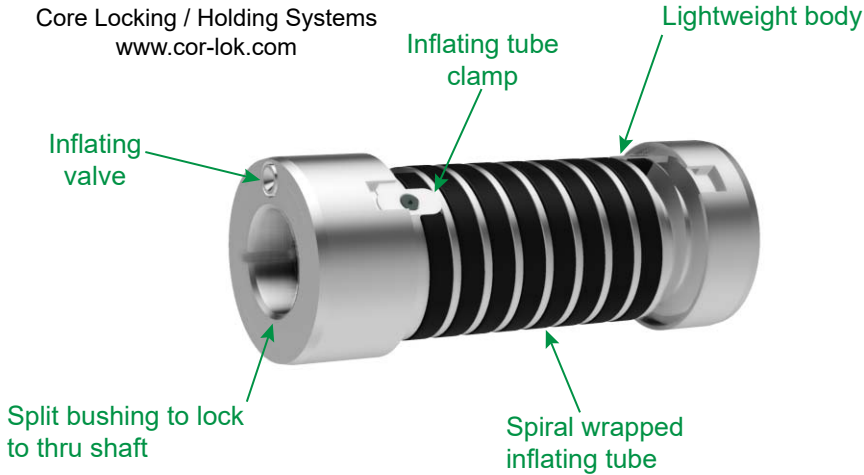

6" Air Chuck

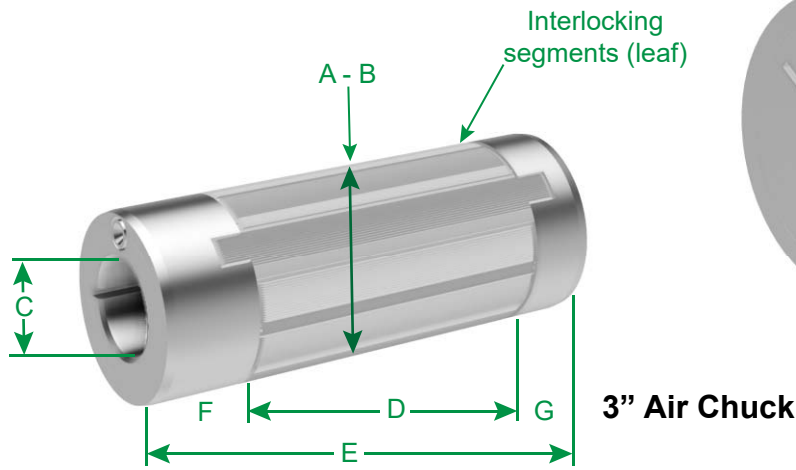

Core size	A Deflated Diameter	B Inflated Diameter	C Bore Range	D Expanding Length	E Overall length	F End cap, valve end	G End cap, plain end	Approx. weight
3	2-15/16	3-1/8	up to 1-3/4	5	7.5	1.5	1	2 lbs
4	3-15/16	4-3/16	up to 2-1/2	5	7.5	1.5	1	2-1/2 lbs
5	4-15/16	5-3/16	up to 3	5	7.5	1.5	1	3 lbs
6	5-15/16	6-3/16	up to 4	6	8.5	1.5	1	12-1/2 lbs
6-3/4	6-11/16	6-7/8	up to 4	6	8.5	1.5	1	13 lbs
7	6-15/16	7-3/16	up to 5	6	8.5	1.5	1	13 lbs
8	7-15/16	8-3/16	up to 6	6	8.5	1.5	1	15 lbs
9	8-15/16	9-3/16	up to 7	6	8.5	1.5	1	17-1/2 lbs
10	9-15/16	10-3/16	up to 8	7	9.5	1.5	1	22 lbs
11	10-15/16	11-3/16	up to 9	7	9.5	1.5	1	25 lbs
12	11-15/16	12-3/16	up to 10	7	9.5	1.5	1	27 lbs

Notes: 1) All dimensions in inches. Thru bores machined .010" - .015" oversized unless otherwise specified.
2) Custom and metric core sizes available, please contact us for more information.



Converter Accessory Corporation

201 Alpha Road, PO Box 188, Wind Gap, PA 18091-0188

www.converteraccessory.com
sales@converteraccessory.com

Phone: 800-433-2413
610-863-6008

Fax: 800-709-1007
610-863-7818